

## Interactive Catalog Replaces Catalog Pages

Honeywell Sensing and Control has replaced the PDF product catalog with the new **Interactive Catalog**. The **Interactive Catalog** is a power search tool that makes it easier to find product information. It includes more installation, application, and technical information than ever before.



**Click this icon to try the new  
Interactive Catalog.**

---

**Sensing and Control**  
Honeywell Inc.  
11 West Spring Street  
Freeport, Illinois 61032



# Basic Switches

## Magnetic Blow-out



**FEATURES**

- Arc resistant case
- Mechanical life of 100,000 operations — 95% survival
- Temperature tolerance to +180°F (82°C)
- Mounting interchangeability with Z switches
- UL recognized

**GENERAL INFORMATION**

MT (single-pole double-throw) magnetic blow-out switches are designed to switch high capacity (125 and 250 VDC) systems. An integral magnet around the contact gap protects the contacts by deflecting the arc. Vents between the cover and housing allow the hot gas to escape. These switches are designed for the control of DC motors, solenoids, etc.

**AVAILABLE TERMINALS**

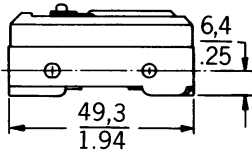

Solder (No listing designation)

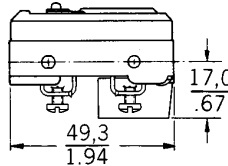

**A28**  
6-32NC x .218" Screws  
will accept up to #12 wire.

**ELECTRICAL RATING**

Circuitry	Electrical Data and UL Codes
Single-pole double-throw unless otherwise noted in order guide 	<b>K</b> Rating established with switch non-polarized 10 amps, 125 vac or vdc; 1/4 hp, 125 vac or vdc. UL Code L 168  Non-polarized: 10 amps res. or 1/4 hp, 125 vdc; 3 amps max. res. 250 vdc. Polarized*: 10 amps res. or 1/2 hp, 125 vdc; 3 amps max. res., 250 vdc.

\*To polarize, connect negative side of line to common terminal. To achieve the same effect, mount switch with brass screws, using a non-magnetic barrier (at least 1/4" thick) between the switch and mounting surface.

**Characteristics:** O.F. – Operating Force;  
 R.F. – Release Force; P.T. – Pretravel;  
 O.T. – Overtravel; D.T. – Differential Travel;  
 O.P. – Operating Position.

**ORDER GUIDE**

Catalog Listing	Recommended For	Electrical Data and UL Codes	O.F. newtons ounces	R.F. min. newtons ounces	P.T. max. mm inches	O.T. min. mm inches	D.T. max. mm inches	O.P. mm inches
<b>MT-4R-A28</b>	Pin plunger SPDT	10 Amps <b>K</b>	3,34-5,0 <b>12-18</b>	1,39 <b>5</b>	1,02 <b>.04</b>	0,13 <b>.005</b>	0,1-0,18 <b>.004-.007</b>	15,9±0,38 <b>.625±.015</b>



Dim. Dwg. Fig. 1

# Basic Switches

## Magnetic Blow-out

MT Series

### ORDER GUIDE



Dim. Dwg. Fig. 2

Catalog Listing	Description	Electrical Data and UL Codes	O.F. max. newtons ounces	R.F. min. newtons ounces	P.T. max. mm inches	O.T. min. mm inches	D.T. max. mm inches	O.P.* mm inches
MT-4RV-A28	Straight lever	10 Amps K	0,56 2	0,14 0.5	12,7 0.5	1,19 .047	2,16 .085	19,1 .750



Dim. Dwg. Fig. 3

MT-4RV2-A28	1.90 inch (48,3mm) lever with hardened steel roller	10 Amps K	0,76 2.75	0,07 0.25	8,89 0.35	0,79 .031	1,65 .065	30,2 1.188
MT-4RV22-A28	1.03 inch (26,2mm) lever with hardened steel roller	10 Amps K	1,25 4.5	0,28 1	5,08 .200	0,38 .015	0,89 .035	31,3 1.234



Dim. Dwg. Fig. 4

MT-4RL-A28	1.95 inch (49,5mm) flexible leaf	10 Amps K	3,34 12	0,28 1	—	1,52 .060 max.	—	19,1 .750
------------	----------------------------------	--------------	------------	-----------	---	----------------------	---	--------------



Dim. Dwg. Fig. 5

MT-4RL2-A28	1.82 inch (46,2mm) flexible leaf with hardened steel roller	10 Amps K	3,34 12	0,28 1	—	1,52 .060 max.	—	30,2 1.188
-------------	-------------------------------------------------------------	--------------	------------	-----------	---	----------------------	---	---------------

Standard Basic Switches

Except where stated \*  $\pm 0,76$  mm  
 $\pm .030$  in.

# Basic Switches

## Magnetic Blow-out

MT Series

MOUNTING DIMENSIONS (For reference only)

**PIN PLUNGER**

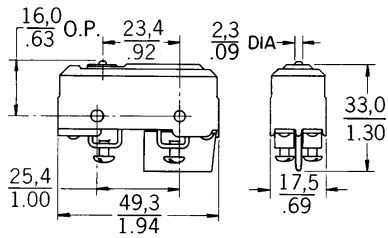

Fig. 1

**STRAIGHT LEVER**

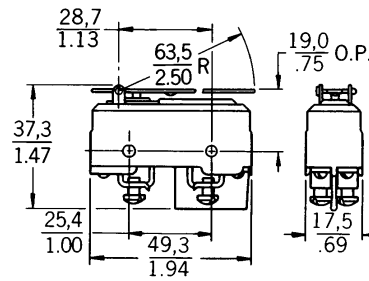

Fig. 2

**ROLLER LEVER**

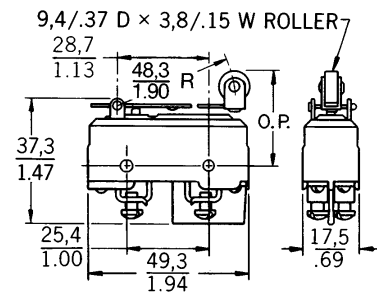

Fig. 3

**FLEXIBLE LEAF**

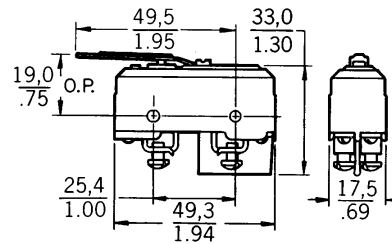

Fig. 4

**FLEXIBLE ROLLER LEAF**

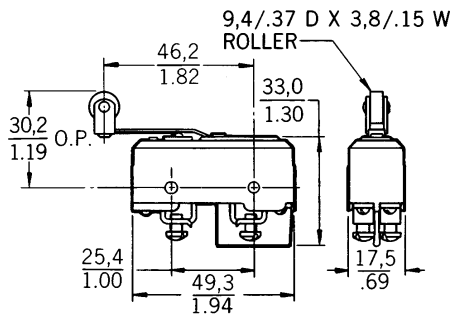

Fig. 5

Mounting holes accept pins or screws of .139" (3,53 mm) diameter.

Key:  $\frac{0,0}{0.00} = \text{mm}$   
 $\frac{0,00}{0.00} = \text{inches}$