

Installation Instructions for the HCH-1000 Series Capacitive Humidity Sensors ISSUE 1 50018326

GENERAL INFORMATION

The HCH-1000 Series is a capacitive polymer sensor designed for relative humidity measurement. The sensor converts humidity value into capacitance, which can be measured electronically.

Polyimide is used as a humidity sensing material because of its inherent IC (Integrated Circuit) processing compatibility, reduced temperature dependence and enhanced resistance against contamination. The HCH-1000 Series is manufactured using semiconductor technology.

STANDARD CHARACTERISTICS

The sensor consists of a grid top electrode, a polyimide layer, and a bottom electrode. The grid top electrode on the bottom electrode provide enhanced sensitivity compared to that of a standard structure. Figure 1 shows the typical response curve in a humidity range of 0% RH to 100% RH.

SENSOR OPERATING RANGE

Although the HCH-1000 Series may not fail beyond the limits, as shown in Figure 2, the specification only applies to operation within the working range.

FIGURE 2: OPERATING RANGE

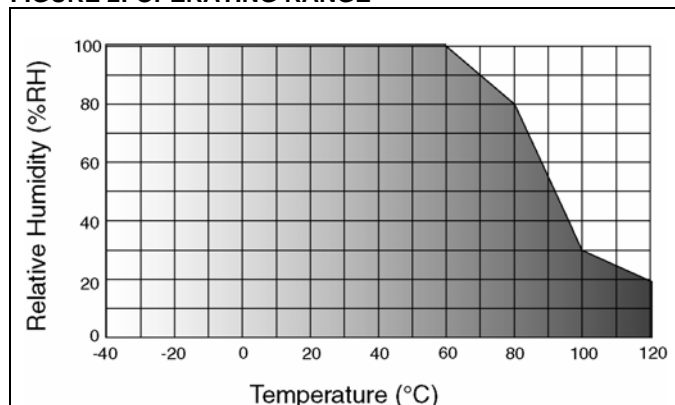
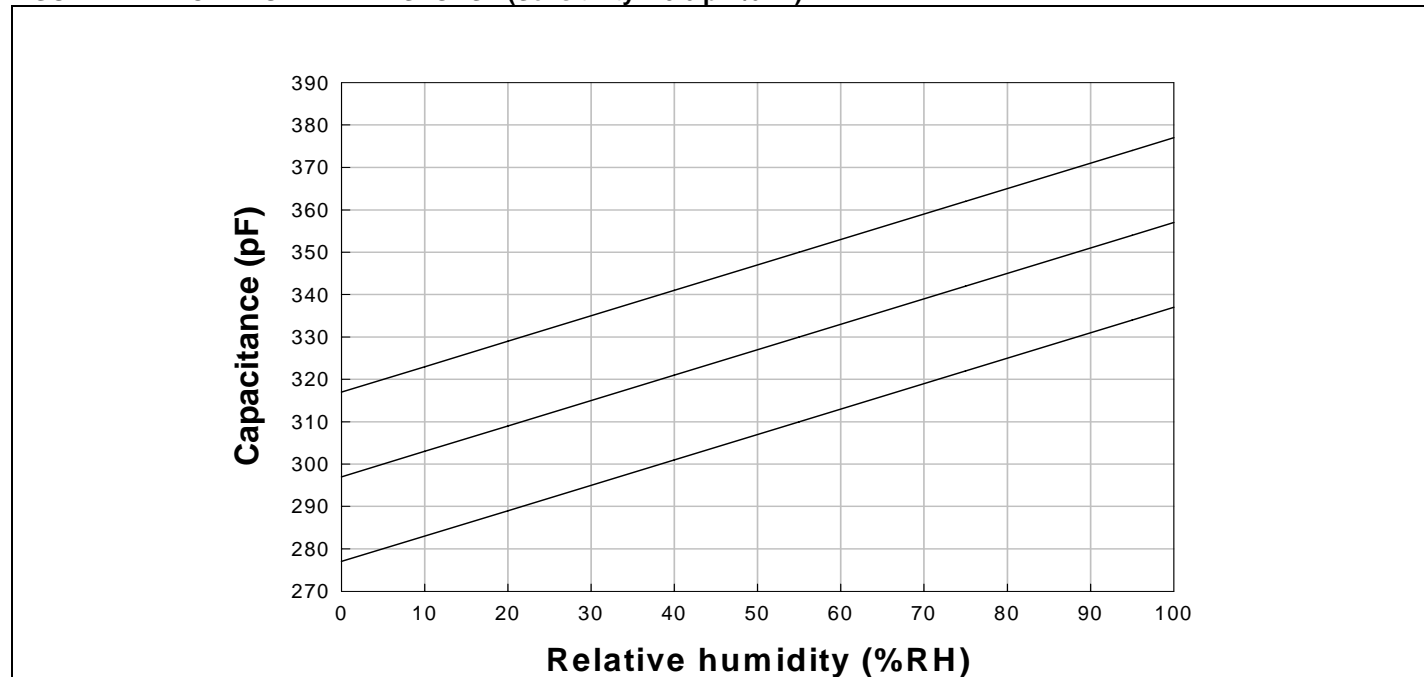

FIGURE 1: TYPICAL HUMIDITY RESPONSE (Sensitivity = 0.6 pF %RH)



HCH-1000 Series Capacitive Humidity Sensors

Issue 1 50018326

SPECIFICATIONS ($T_A = 25\text{ }^\circ\text{C}$ [77 °F], Input Voltage = 1 V_{RMS} , Frequency = 20 kHz)

Characteristic	Min.	Typ.	Max.	Unit	Note
Normal capacitance	310	330	350	pF	at 55% RH
Sensitivity	0.55	0.6	0.65	pF/% RH	10% RH to 95% RH
Humidity hysteresis	–	±2	–	% RH	–
Linearity	–	±2	–	% RH	–
Response time	–	15	–	sec	30% RH to 90% RH
Temperature coefficient	0.15	0.16	0.17	pF/°C	5 °C to 70 °C [41 °F to 158 °F]
Long-term stability (drift)	–	0.2	–	% RH/year	–
Operating temperature range	-40 [-40]	–	120 [248]	°C [°F]	–
Operating humidity range	0%	–	100%	RH	–
Operating frequency range	1	–	100	kHz	–

BASIC CAPACITANCE CHARACTERISTICS

Capacitance is measured by applying 1 V_{RMS} at 20 kHz at 25 °C. The sensor characteristic is determined by the following formula:

$$C_c(\%RH) = C_s \text{ at } 55\%RH + S \times [(\%RH(C_M) - \%RH(C_s))]pF$$

Where,

S	Sensitivity (pF/%RH)
$C_c(\%RH)$	Calculated capacitance at the measured relative humidity
$C_s \text{ at } 55\%RH$	Standard capacitance value at 55% RH
$\%RH(C_M)$	Measured relative humidity value
$\%RH(C_s)$	Standard relative humidity value (55% RH)

Figure 3 shows the typical characteristic curve. The average increase in capacitance value within the working range of 10% RH to 95% RH is typically 56 pF.

$$\%RH(C_c) = \frac{C_M(\%RH) - C_s \text{ @ } 55\%RH}{S} + \%RH(C_s)$$

Where,

S	Sensitivity (pF/%RH)
$C_M(\%RH)$	Measured capacitance value
$C_s \text{ at } 55\%RH$	Standard capacitance value at 55% RH
$\%RH(C_c)$	Calculated relative humidity value at the measured capacitance
$\%RH(C_s)$	Standard relative humidity value (55% RH)

FIGURE 3: BASIC CAPACITANCE (At 25 °C, 1 V_{RMS} , 20 kHz)

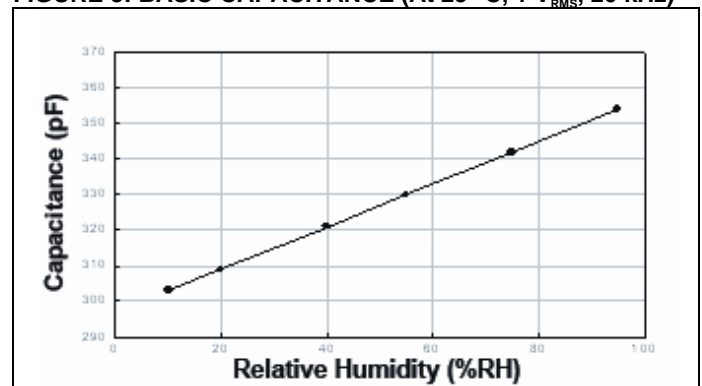

HYSTERISIS CHARACTERISTICS

Figure 4 shows the hysteresis curve. The hysteresis formula is:

$$HysteresisValue = C(20\%RH \Rightarrow 95\%RH) - C(95\%RH \Rightarrow 20\%RH)$$

The hysteresis value is measured under 1 pF. The hysteresis of measured samples indicates between ±3% RH at each humidity point.

FIGURE 4: HYSTERISIS CHARACTERISTICS

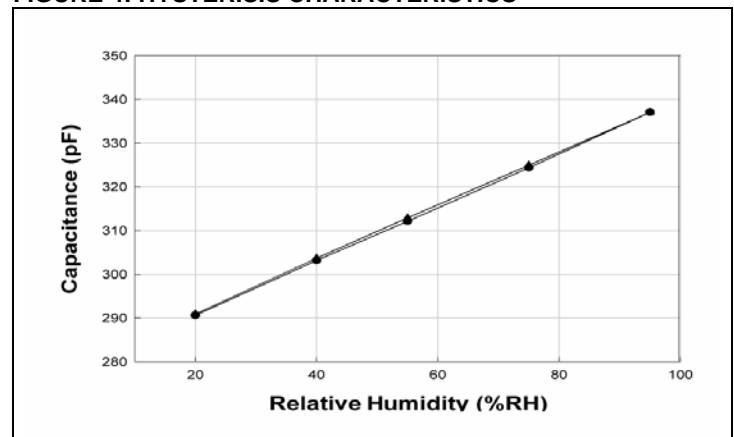

HCH-1000 Series Capacitive Humidity Sensors

Issue 1 50018326

FIGURE 5: TEMPERATURE CHARACTERISTICS
(At 1 V_{RMS}, 20 kHz)

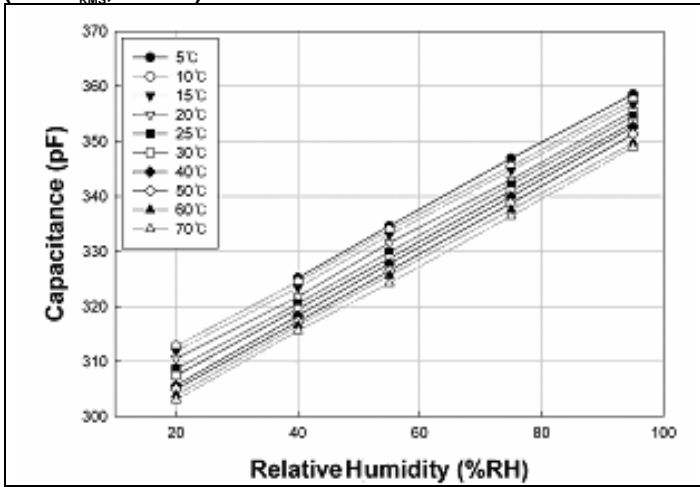

FIGURE 7: SHORT-TERM STABILITY

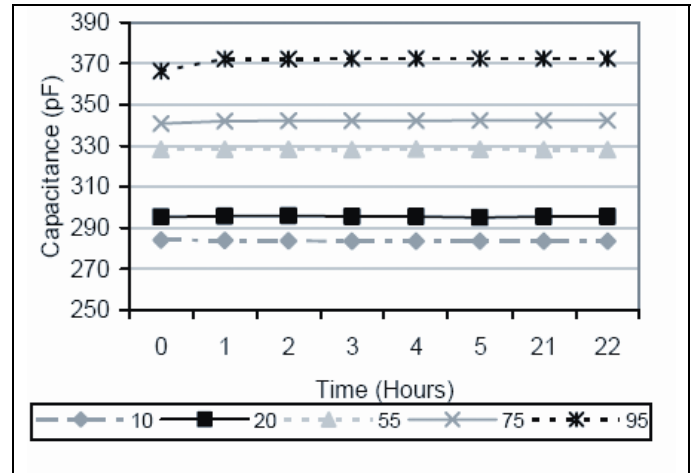

FIGURE 6: FREQUENCY CHARACTERISTICS

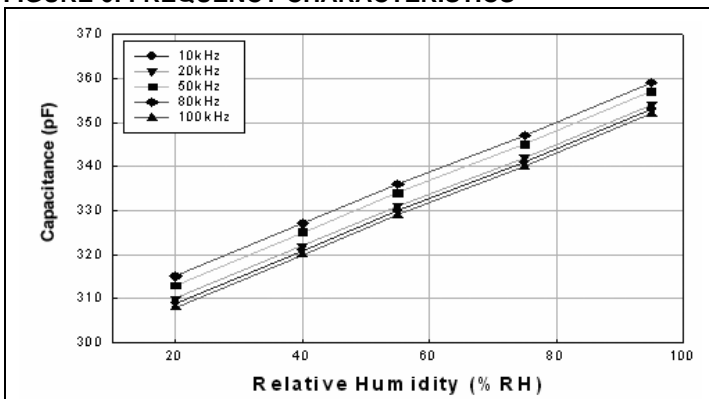
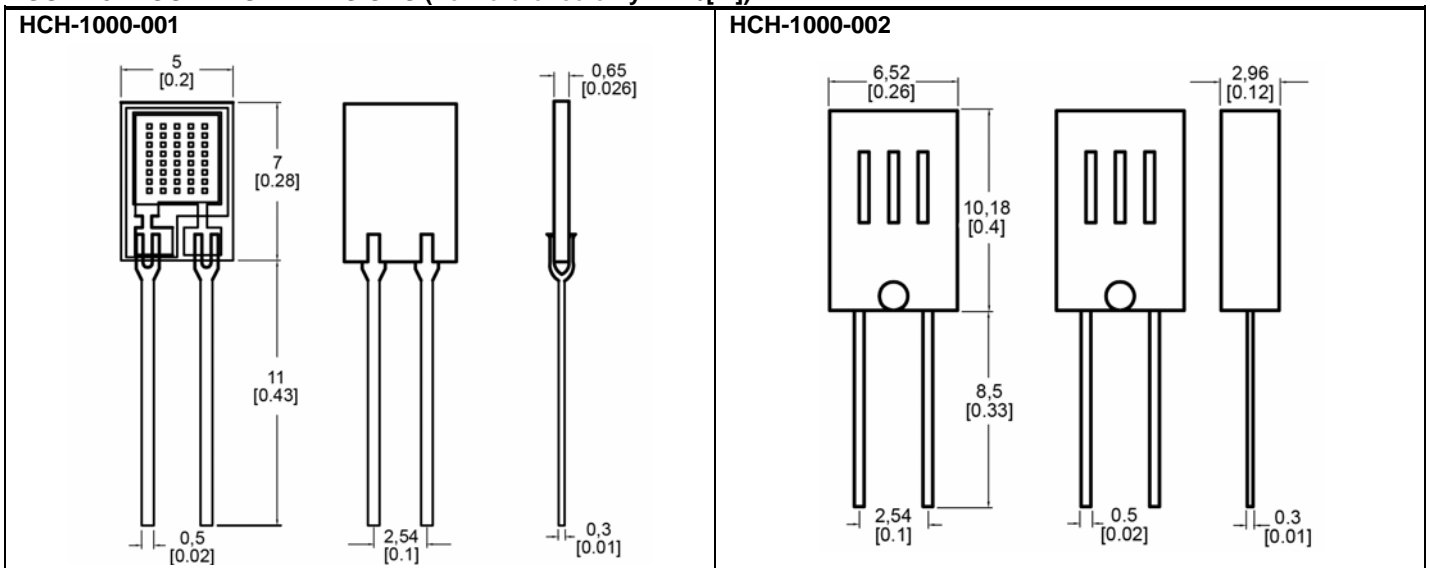

FIGURE 8: MOUNTING DIMENSIONS (For reference only: mm/[in])



HCH-1000 Series Capacitive Humidity Sensors

Issue 1 50018326

ENVIRONMENTAL TEST SYSTEM

Figure 9 depicts environmental testing. The devices are characterized at 25 °C [77 °F] between 20% RH and 95% RH. The meter is set to measure capacitance at 1 V and 20 kHz.

For precise measurement, a hygrometer is compared with the humidity of the temperature humidity chamber.

The data output indicates the effect of sensor characterization before/after the environmental tests.

FIGURE 9: ENVIRONMENTAL TEST SYSTEM DIAGRAM

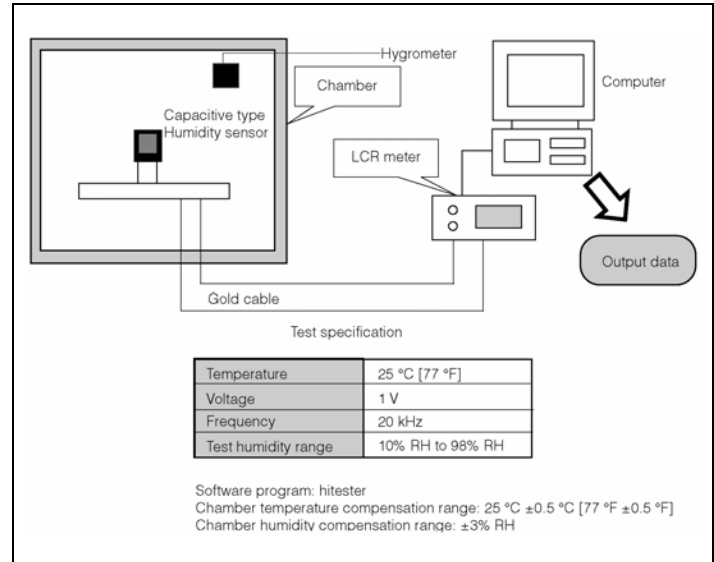

WARNING

PERSONAL INJURY

DO NOT USE these products as safety or emergency stop devices or in any other application where failure of the product could result in personal injury.

Failure to comply with these instructions could result in death or serious injury.

WARRANTY/REMEDY

Honeywell warrants goods of its manufacture as being free of defective materials and faulty workmanship. Honeywell's standard product warranty applies unless agreed to otherwise by Honeywell in writing; please refer to your order acknowledgement or consult your local sales office for specific warranty details. If warranted goods are returned to Honeywell during the period of coverage, Honeywell will repair or replace, at its option, without charge those items it finds defective. **The foregoing is buyer's sole remedy and is in lieu of all other warranties, expressed or implied, including those of merchantability and fitness for a particular purpose. In no event shall Honeywell be liable for consequential, special, or indirect damages.**

While we provide application assistance personally, through our literature and the Honeywell web site, it is up to the customer to determine the suitability of the product in the application.

Specifications may change without notice. The information we supply is believed to be accurate and reliable as of this printing. However, we assume no responsibility for its use.

SALES AND SERVICE

Honeywell serves its customers through a worldwide network of sales offices, representatives and distributors. For application assistance, current specifications, pricing or name of the nearest Authorized Distributor, contact your local sales office or:

E-mail: info.sc@honeywell.com

Internet: www.honeywell.com/sensing

Phone and Fax:

Asia Pacific +65 6355-2828
+65 6445-3033 Fax
Europe +44 (0) 1698 481481
+44 (0) 1698 481676 Fax
Latin America +1-305-805-8188
+1-305-883-8257 Fax
USA/Canada +1-800-537-6945
+1-815-235-6847
+1-815-235-6545 Fax

Sensing and Control

1985 Douglas Drive North

Minneapolis, MN 55422

www.honeywell.com/sensing

50018326-1-EN IL50 GLO Printed in USA
July 2007

Copyright © 2007 Honeywell International Inc. All rights reserved.

Honeywell